



AC Hydraulic^{A/S}

NO COMPROMISE



SD32PHL / SD40PHL

- Ⓚ Ophængsliste for saksedonkraft
- Ⓜ Support arms for jacking beam
- Ⓛ Aufhängungen für Scherenheber
- Ⓧ Jeux d'accroches pour traverse de levage

Lift	Model, type, (evt. årgang og andre bemærkninger)	Varenr.
Lift	Model, Type, (Year and other comments)	Item No.
Hebebühne	Modell, Typ, (Baujahr und weitere Hinweise)	Artikel Nr.
Pont	Modèle, Marque (année et d'autres remarques)	Référence
ATT	HYMAX X6000	63 269 10
Cascos	C470/460	63 262 00
Nussbaum	Unilift 6000 - 8000	63 269 10
	Combilift 4,80H	63 269 00
	Unilift 5000 NT/CLT fra/von/from/de 04/2013	63 283 00
	4.65 (m. lys, with lifth, mit Licht, avec éclairage)	63 353 00
Omer	Fox 50	63 280 00
Ravaglioli	4650 / 4800 (m kant, with edge, mit Kante, avec rail)	63 263 00
Rotary	RJ-40X	63 281 00
Stenhøj	Maxi 80, Maxi 100	63 265 50
	Biglift 550 (alternativ : 63 264 75)	63 262 00
	Major 7230-60S	63 264 25
	Major 7230 lifte fra 2012 u. kant. KUN anvendelig på lifte uden lys eller med LED lys monteret. For lifts from 2012 without rail. Only for lifts without light or w/LED. . Für Bühnen von 2012 ohne Kante. Nur für Bühnen ohne Licht oder mit LED. Pour ponts à partir de 2012 sans rail. Seulement pour ponts sans éclairage ou avec LED.	63 282 00
Sice	PSR 50 CTLT	63 270 00
Stertil-Koni	ST4100	63 262 00
	ST4070, ST4400, ST4055	63 353 00
	ST4120	63 265 00
	Sikkerhedskit til, safety kit, for, Aushubsicherung für, jeu de sécurité pour : 63 265 00	63 352 14
Werther	480	63 265 50

DK

Denne liste er baseret på enkelte eksemplarer af de pågældende lifte. AC tager forbehold for eventuelle ændringer i liftproducenternes produkter. Erfaringer med kombineret af lifte og ophæng modtages gerne.

GB

This list is based upon a few examples of the lift in question and is only valid provided the lift manufacturers do not make any changes. Please inform us, if you have any experience with different combinations of lifts and support arms.

D

Diese Liste ist auf einzelne Exemplare der betreffenden Hebebühne basiert, darum nimmt AC den Vorbehalt, daß die Produkte eventuell vom Produzenten geändert werden können. Wir würden Sie freundlichst bitten, uns Ihre Erfahrungen mit der Kombination Lift / Aufhängungen weiterzugeben.

F

Cette liste est élaborée sur la base de quelques exemplaires de ponts et la liste est seulement valable sous réserves que le fabricant n'a pas fait de modifications. Veuillez nous faire savoir plus sur vos expériences avec différentes combinaisons de ponts et de jeux d'accroches.

63 262 00

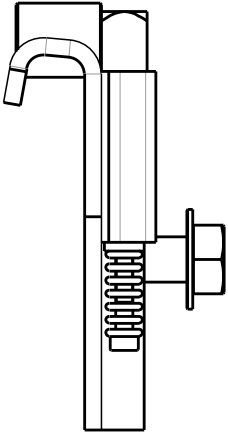

63 263 00

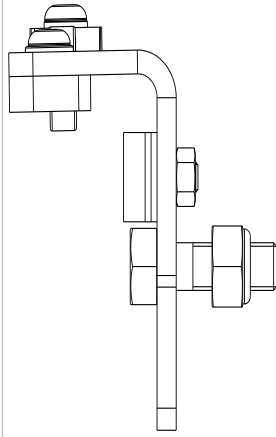

63 264 00

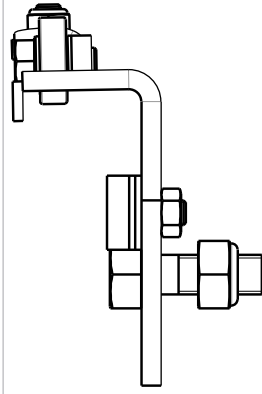

63 264 25

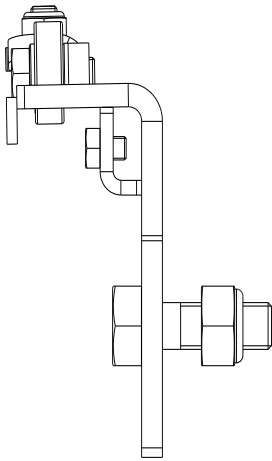

63 264 75

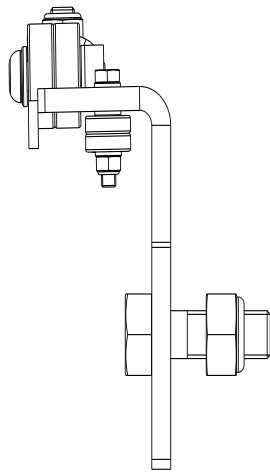

63 265 00

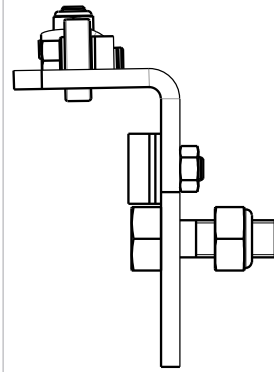

63 265 50

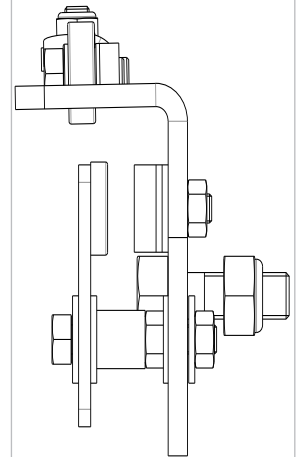

63 269 00

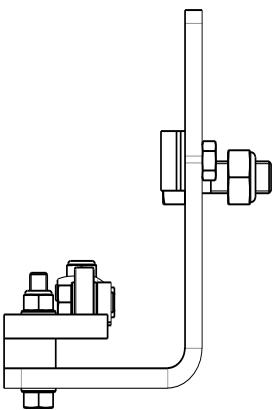

63 269 10

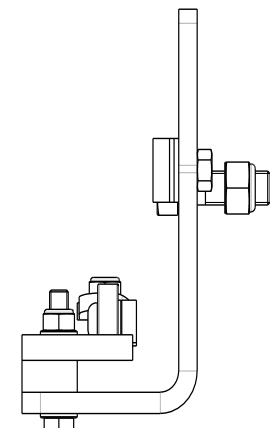

63 270 00

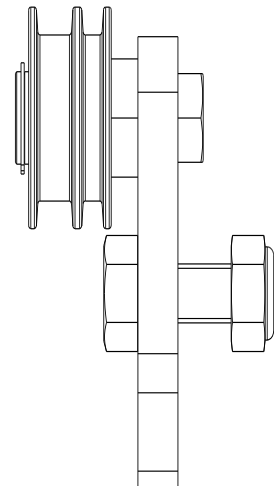

63 272 00

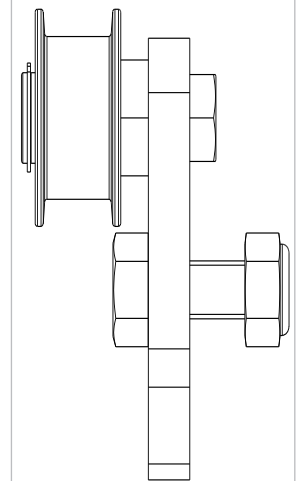

63 273 00

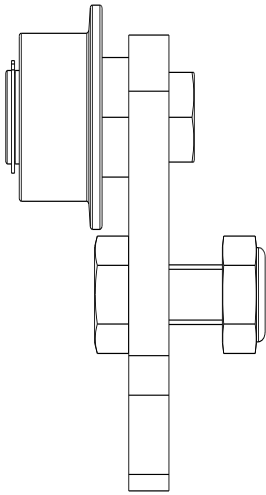

63 274 00

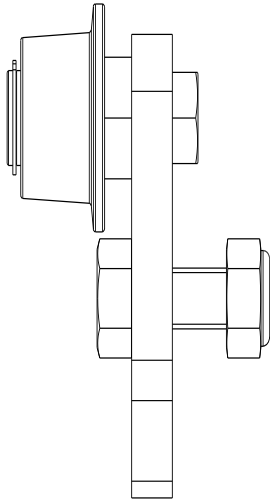

63 275 00

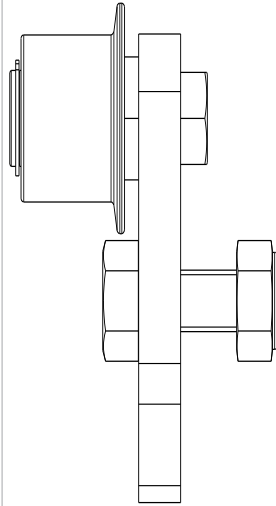

63 275 10

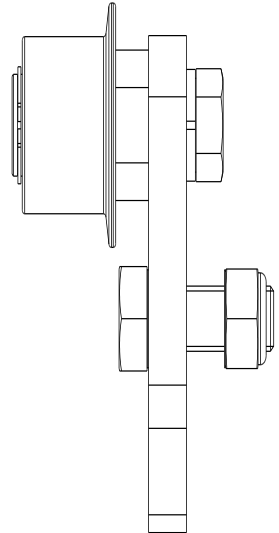

63 280 00

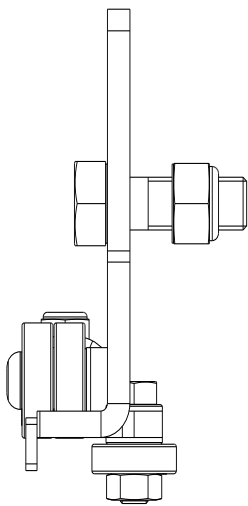

63 281 00

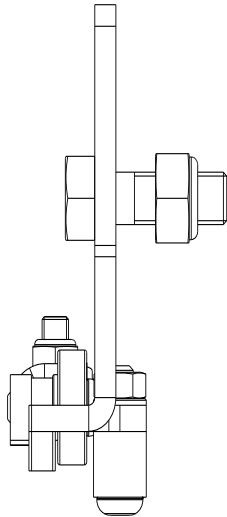

63 282 00

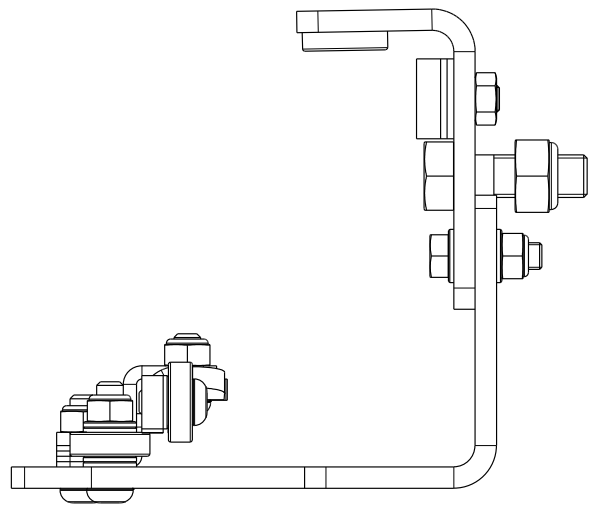

63 283 00

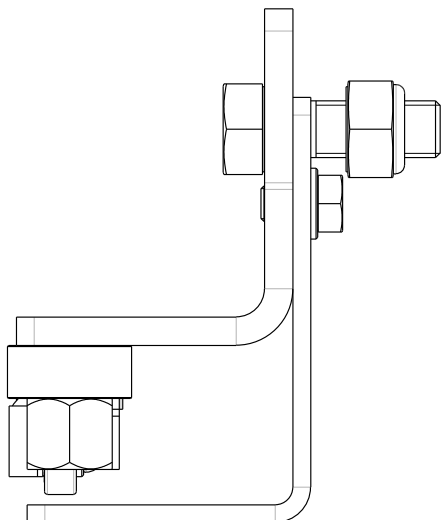

63 353 00

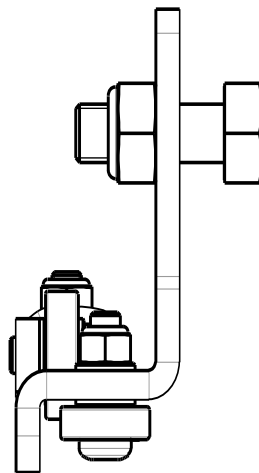

Varenr. Article no. Artikel Nr. Référence	A	B	C	D	E	L		H		W	
						min.	max.	min.	max.	min.	max.
						63 262 00	-	20	(29)	ø26	-
63 263 00	-	-	(48)	ø35	-	144	208	27	91	824	1264
63 264 00	-	-	(46,5)	ø35	-	166	230	3	67	824	1264
63 264 25	-	-	30,5	ø35	35	165,5	229,5	3,5	67,5	839	1279
63 264 75	27,5-44	3-20	15-32	ø35	35	166	230	3	67	852	1292-1326
63 265 00	-	-	(49)	ø35	-	157	221	14	78	824	1264
63 265 50	-	-	(49)	ø35	-	157	221	14	78	824	1264
63 269 00	-	-	-	ø35	-	-14	50	185	249	828	1268
63 269 10	-	-	-	ø35	-	-14	50	185	249	828	1268
63 270 00	14,5	7/12,5	33,5	ø45	52,5	22	181	54	213	840	1280
63 272 00	14,5	24	33,5	ø45	52,5	22	181	54	213	840	1280
63 273 00	16	26	32	ø45	52,5	22	181	54	213	840	1280
63 274 00	16	26	32	ø45	52,5	22	181	54	213	840	1280
63 275 00	10	33	37	ø43,5	52	23	182	53	212	830	1270
63 275 10	17	33	37	ø43,5	52	23	182	53	212	844	1284
63 280 00	5,5-18	7-19,5	23,5-16	ø35	35	20	84	149	213	807	1247-1272
63 281 00	13-0,5	2-14,5	32,5-20	ø35	35	21	85	150	214	797	1237
63 282 00	-	-	(45)	-	(15)	164	178	57	71	840	1264
63 283 00	37,5	-	(35)	ø30	(41)	21	60	175	214	871	1311
63 353 00	37-27	2-12	32-22	ø35	35	44	108	127	191	850	1290

Ophæng for saksedonkrafte
Support arms for jacking beams
Aufhängungen für Scherenheber
Jeux d'accroches pour traverses de levage

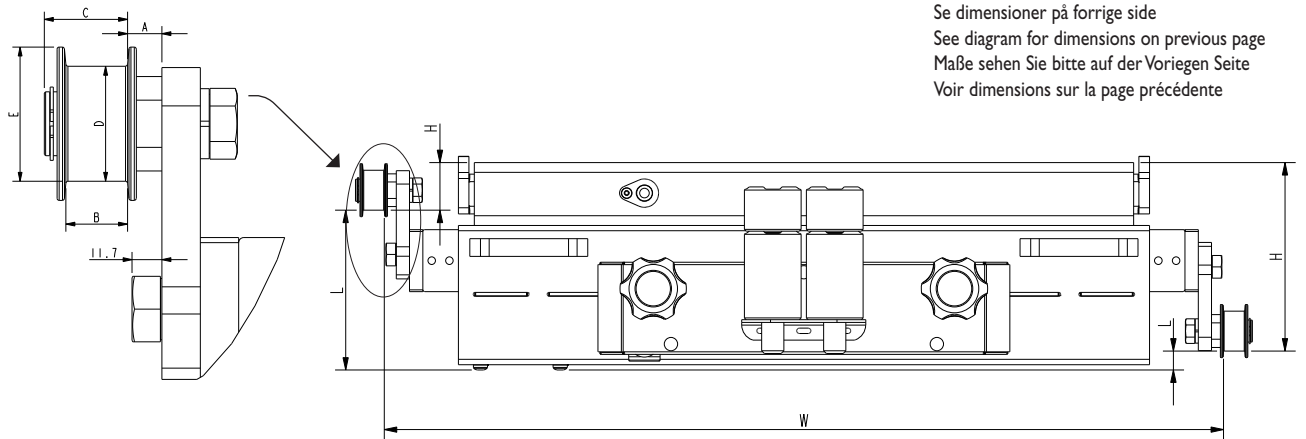

<p>A Teleskopudtræk/Løftearme mm Telescopic arms mm. Teleskopauszug/Hubarme mm Bras télescopique mm</p> <p>B Slaglængde mm Stroke mm Kolbenhub mm Course mm</p>	<p>C Rammehøjde mm Frameheight mm Chassishöhe mmm Hauteur de cadre mm</p> <p>D Rammebredde mm Framewidth mm Rahmenbreite mm Longeur de cadre mm</p>	<p>E Bredde incl. udtræk mm Frame width mm Auszug Aufhängung mm Longeur de bras rallonge mm</p> <p>F Løfteramme bredde mm Lifting frame width mm Hubrahmen Breite mm Largeur de cadre de levage mm</p>	<p>G Min. højde mm Min. height mm Min. Höhe mm Hauteur mini mm</p> <p>H Total bredde mm Total width mm Gesamtbreite mm Largeur totale mm</p>
---	---	--	--

SD40PHL

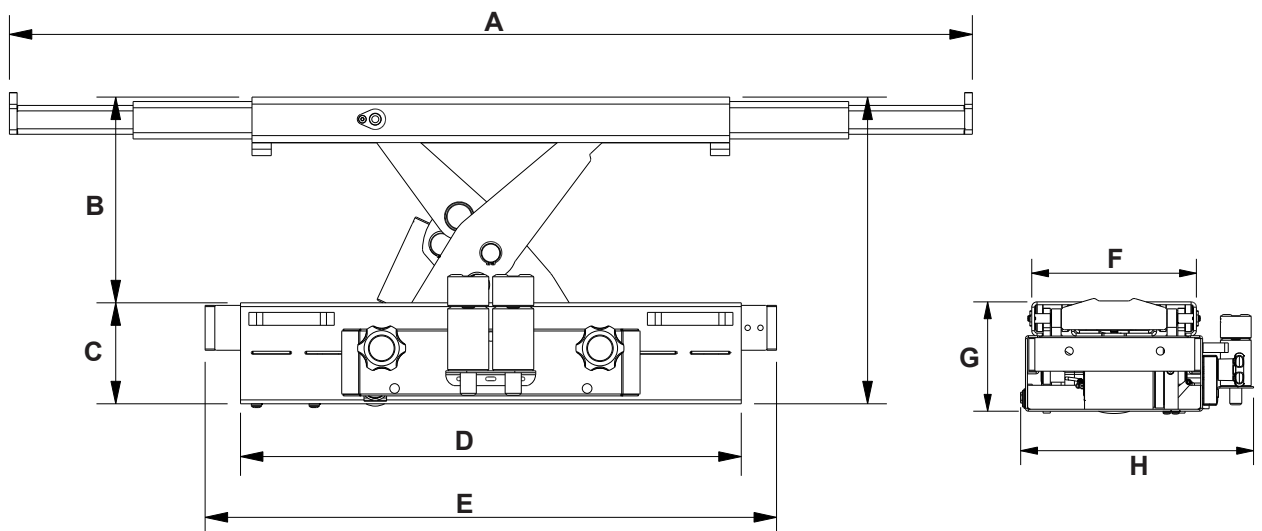

Model	A	B	C	D	E	F	G	H
SD40PHL	780-1500	70-320	160	780	780-1220	343	230	485

MÅLSKEMA LIFT

FL - Frihjulsløfter 6 t 12 t 16 t 20 t

SD - Saksedonkraft 2 t 2,6 t 3,2 t 4 t

Liftfabrikant: _____ Model: _____ Kapacitet: _____ Årgang: _____

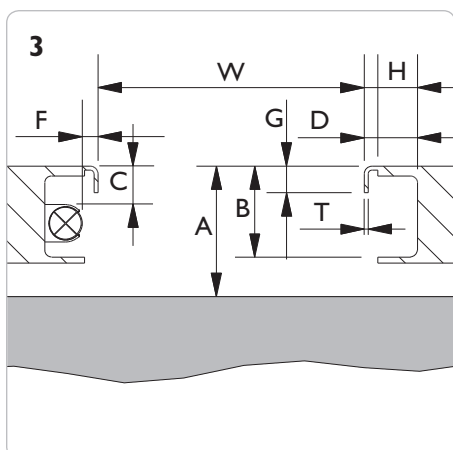
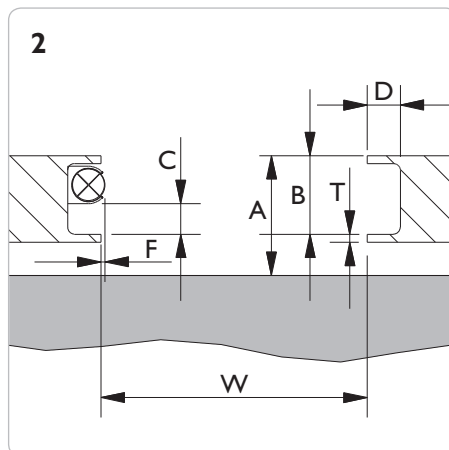
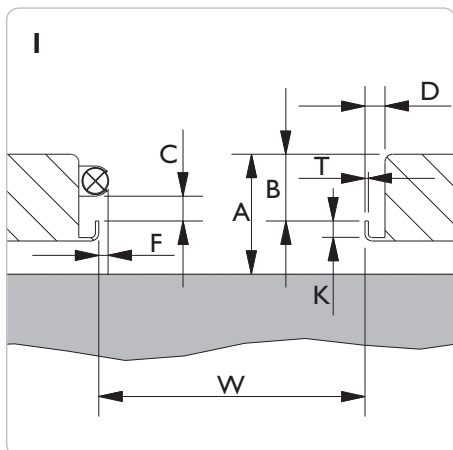

4 Skitse

Skitse nr.: _____

- W = _____ mm
- A = _____ mm
- B = _____ mm
- D = _____ mm
- G = _____ mm
- H = _____ mm
- K = _____ mm
- T = _____ mm

Hvis liften er forsynet med belysning  eller andre fremspring udfyldes mål C og F:

- C min. = _____ mm
- F max. = _____ mm

Skinneprofil

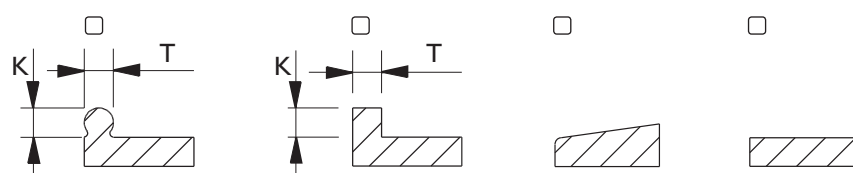

NB: Det er købers risiko/ansvar at opgive data er korrekte og fyldestgørende. Liften skal altid være konstrueret og godkendt for montering af hjælpedonkraft. **Jf. EN1493:1998 må hjælpedonkraftens kapacitet ikke overskride 0,66 x liftens kapacitet.** (En 2 tons donkraft på en 3 tons lift er ok - men ikke en 2,6 tons).

Dato: _____

Opmålt af: _____

Forhandler: _____

Underskrift: _____

MÅLSKEMA GRAV

- | | | | |
|---------------------------------------|---|-----------------------------|---|
| GD - Gravdonkraft | <input type="checkbox"/> 10 t <input type="checkbox"/> 15 t <input type="checkbox"/> 20 t | FL - Frihjulsløfter | <input type="checkbox"/> 6 t <input type="checkbox"/> 12 t <input type="checkbox"/> 16 t <input type="checkbox"/> 20 t |
| GDT - Teleskopisk gravdonkraft | <input type="checkbox"/> 15 t | SD - Saksedonkraft | <input type="checkbox"/> 2 t <input type="checkbox"/> 2,6 t <input type="checkbox"/> 3,2 t <input type="checkbox"/> 4 t |
| GGD - Gulvgravdonkraft | <input type="checkbox"/> 15 t | ABT - Aflastningsbro | <input type="checkbox"/> 20 t |
| AB - Aflastningsbro | <input type="checkbox"/> 20 t | | |

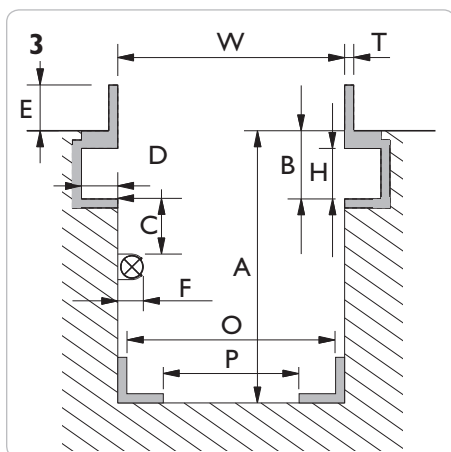
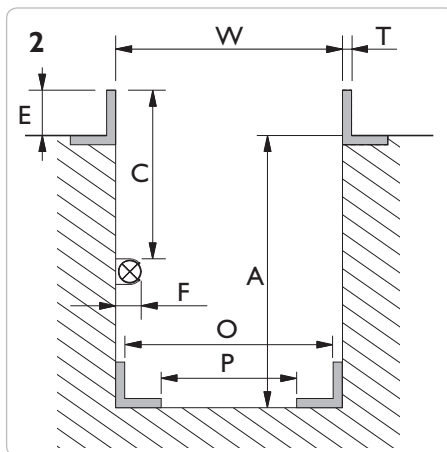
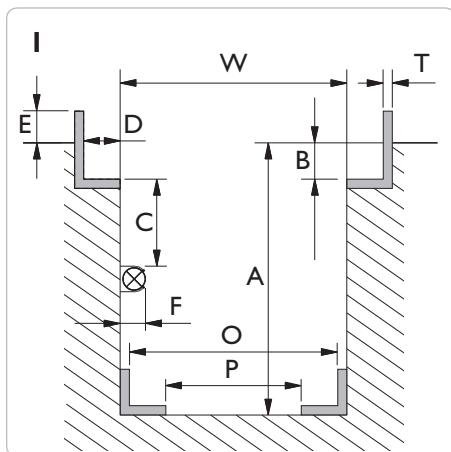

4 Skitse

Skitse nr.: _____

Mål venligst omhyggeligt flere steder i graven. **NB: Max 12 mm variation mellem W min. og W max. i hele gravens længde.**

W min. = _____ mm

W max. = _____ mm

A min. = _____ mm

B = _____ mm

D = _____ mm

E = _____ mm

H = _____ mm

T = _____ mm

Hvis graven er forsynet med belysning eller andre fremspring udfyldes mål C og F:

C min. = _____ mm

F max. = _____ mm

GGDI50S - Gulvgravdonkraft:

O min. = _____ mm

O max. = _____ mm

P min. = _____ mm

P max. = _____ mm

Højde i forhold til gulv

Løftesadlens overkant **uden** tilbehør (travers, støttebuk eller forlænger) ønskes:

over værkstedsgulv _____ mm

i niveau med værkstedsgulv

under værkstedsgulv _____ mm

Sadlen placeres +/- 50 mm ift. ønsket niveau

Tilbehør

Bemærk at evt. montering af travers eller støttebuk forøger min. højde:

Travers T4-1 = + 100 mm

Travers T5-1 = + 95 mm

Travers T6-1 = + 55 mm

Travers T4-2 = + 145 mm

Travers T5-2 = + 140 mm

Travers T6-2 = + 90 mm

S200 = + 65 mm

Rulletype / Skinneprofil

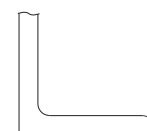
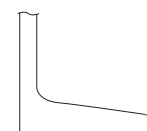

Konisk/skrå Cylindrisk/plan

NB: Det er købers risiko/ansvar at opgive data er korrekte og fyldestgørende, samt at graven er konstrueret og tilstrækkeligt forankret til den ønskede kapacitet.

Dato:

Opmålt af:

Forhandler:

Underskrift:



LIFT SPECIFICATION FORM

FL - Heavy duty jacking beam 6 t 12 t 16 t 20 t
 SD - Jacking beam 2 t 2,6 t 3,2 t 4 t

Lift: _____ **Model:** _____ **Capacity:** _____ **Year:** _____

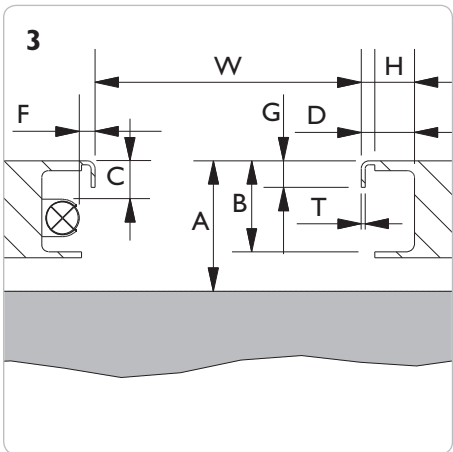
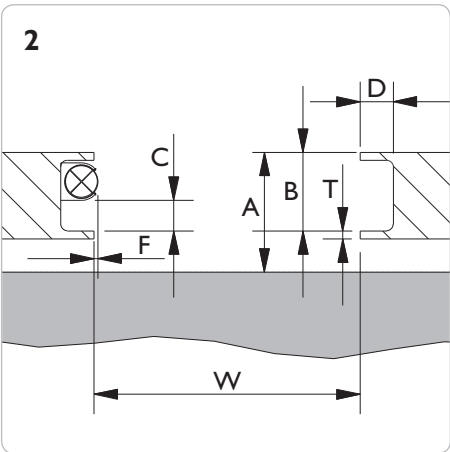
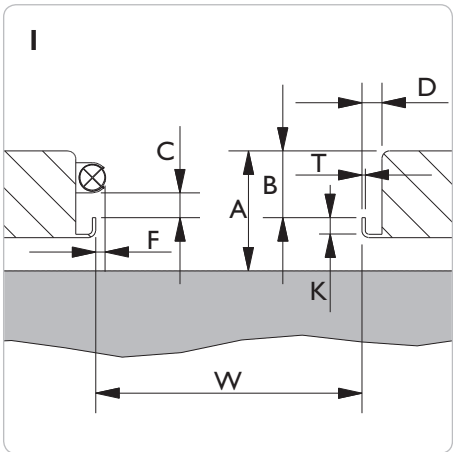

4 Drawing

Drawing no.: _____
 W = _____ mm
 A = _____ mm
 B = _____ mm
 D = _____ mm
 G = _____ mm
 H = _____ mm
 K = _____ mm
 T = _____ mm

If the lift is mounted with light or other obstructing parts, please fill out C and F:

C min. = _____ mm
 F max. = _____ mm

Rail profile

PLEASE NOTE: It is the customer's responsibility that the given measures are correct and sufficient.
N.b. EN1493:1998 the capacity of the jacking beam cannot exceed 0,66 x the capacity of the lift.
 (A 2 t jacking beam on a 3 t lift is okay - but not a 2,6 t).

Date: _____	Measured by: _____	Dealer: _____	Signature: _____
-----------------------	------------------------------	-------------------------	----------------------------



PIT SPECIFICATION FORM

- GD** - Pit jack 10 t 15 t 20 t
- GDT** - Telescopic pit jack 15 t
- GGD** - Floor pit jack 15 t
- AB** - Support bridge 20 t

- FL** - Heavy duty jacking beam 6 t 12 t 16 t 20 t
- SD** - Jacking beam 2 t 2,6 t 3,2 t 4 t
- ABT** - Support bridge 20 t

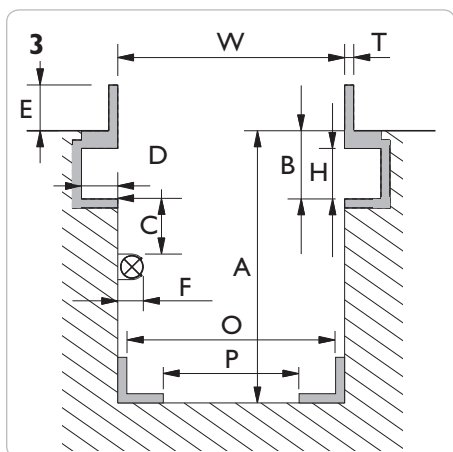
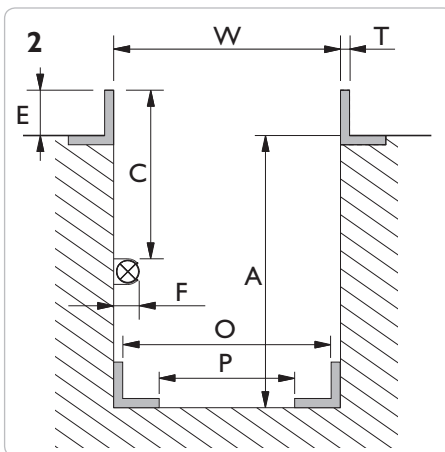
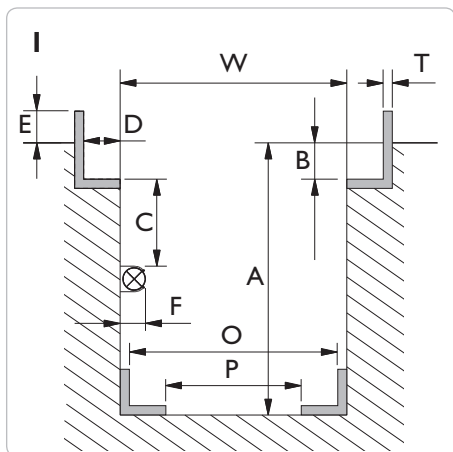

4 Drawing

Drawing no.: _____

Please measure various places along the length of the pit. **Max 12 mm variation between W min og W max. throughout the pit length**

W min. = _____ mm

W max. = _____ mm

A min. = _____ mm

B = _____ mm

D = _____ mm

E = _____ mm

H = _____ mm

T = _____ mm

If the pit is mounted with light or other obstructing parts, please fill out C and F:

C min. = _____ mm

F max. = _____ mm

GGDI50S - Floor pit jack

O min. = _____ mm

O max. = _____ mm

P min. = _____ mm

P max. = _____ mm

Placing of saddle

The placing of top saddle **excluding** cross beam adaptor, safety stand and extensions is required:

- above workshop floor _____ mm
- levelling with workshop floor
- below workshop floor _____ mm

The top of the cylinder will be positioned +/- 50 mm according to requested level

Option

Please note, mounting of different options will increase the min. height:

- Cross beam T4-1 = + 100 mm
- Cross beam T5-1 = + 95 mm
- Cross beam T6-1 = + 55 mm
- Cross beam T4-2 = + 145 mm
- Cross beam T5-2 = + 140 mm
- Cross beam T6-2 = + 90 mm
- Safety stand S200 = + 65 mm

Rolltype / Rail profile

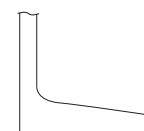

Conical/
tilted

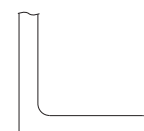

Cylindrical/
straight

PLEASE NOTE: It is the customer's responsibility that the given measures are correct and sufficient and that the pit is built and anchored to withstand the designated loading.

Date:

Measured by:

Dealer:

Signature:

MAßBLATT HEBEBÜHNE

FL - Achsfreiheber 6 t 12 t 16 t 20 t

SD - Scherenheber 2 t 2,6 t 3,2 t 4 t

Hebebühne: _____ Modell: _____ Kapazität: _____ Baujahr: _____

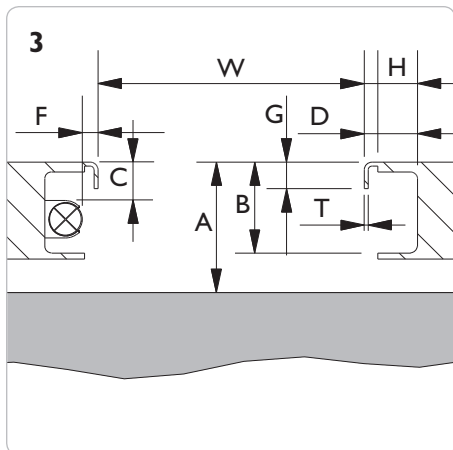
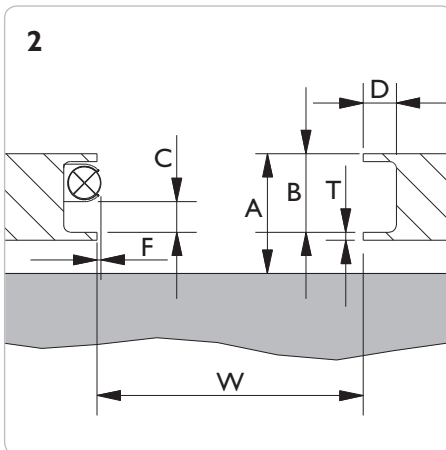
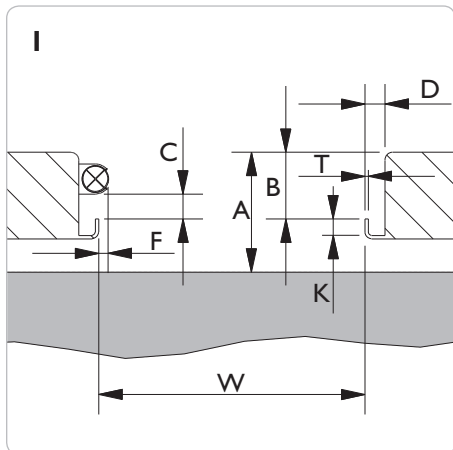

4 Skizze

Skizze Nr.: _____

- W = _____ mm
- A = _____ mm
- B = _____ mm
- D = _____ mm
- G = _____ mm
- H = _____ mm
- K = _____ mm
- T = _____ mm

Falls die Bühne mit Licht  oder andere Hindernisse ausgestattet ist, bitte C und F ausfüllen:

- C min. = _____ mm
- F max. = _____ mm

Befestigung (bitte markieren)

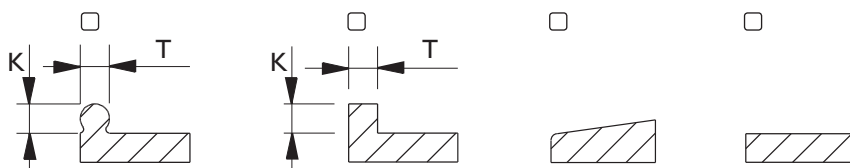

Der Käufer trägt die volle Verantwortung für eine korrekte Bemaßung. Die Hebebühne muss für die Montage eines Heber immer konstruiert und genehmigt sein. **Vgl. ENI 493:1998, Kapazität des Hebers darf 0,66 x Kapazität der Hebebühne nicht überschreiten.** (ein 2 t Heber ist ok auf einer 3 t Hebebühne ist ok - aber nicht ein 2,6 t).

Datum: _____

Maßangaben von: _____

Händler: _____

Unterschrift: _____

MAßBLATT GRUBE

GD - Grubenheber 10 t 15 t 20 t
GDT - Teleskopischer Grubenheber 15 t
GGD - Bodenlauf. Grubenheber 15 t
AB - Abstützbrücke 20 t

FL - Achsfreiheber 6 t 12 t 16 t 20 t
SD - Scherenheber 2 t 2,6 t 3,2 t 4 t
ABT - Abstützbrücke 20 t

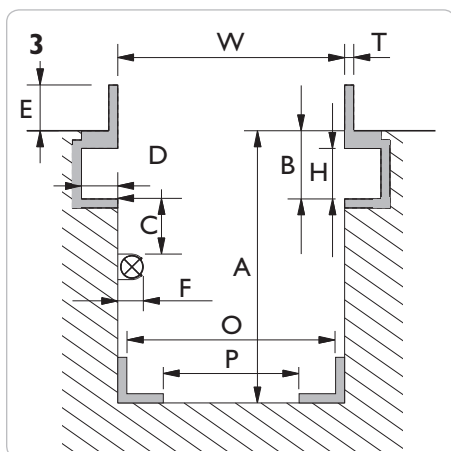
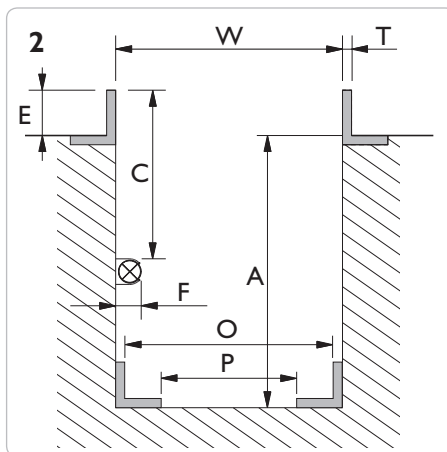
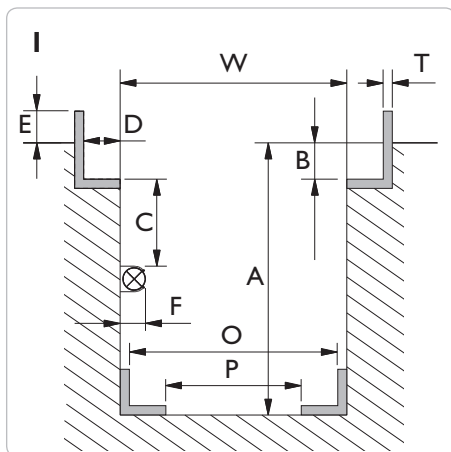

4 Skizze

Skizze Nr.: _____

Messen Sie sorgfältig an verschiedenen Stellen der Grube. **Bitte beachten Sie: W min. und W max. darf max. 12 mm variieren**

W min. = _____ mm

W max. = _____ mm

A min. = _____ mm

B = _____ mm

D = _____ mm

E = _____ mm

H = _____ mm

T = _____ mm

Falls die Bühne mit Licht  oder anderen Hindernissen ausgestattet ist, bitte C und F ausfüllen:

C min. = _____ mm

F max. = _____ mm

GGDI50S - Grubenheber

O min. = _____ mm

O max. = _____ mm

P min. = _____ mm

P max. = _____ mm

Plazierung des Hubsattels

Die Oberkante des Hubsattels **ohne** Zubehör (Traverse, Sicherheitsgestell oder Verlängerung):

- über Werkstattboden _____ mm
- niveaugleich mit Werkstattboden
- unter Werkstattboden _____ mm

Die Höhe des Sattels wird um +/- 50 mm gemäß Ihrem Wunsch positioniert

Zubehör

Bitte beachten Sie, daß eine eventuelle Montierung von Traverse oder Sicherheitsgestell die min. Höhe erhöht:

- Traverse T4-1 = + 100 mm
- Traverse T5-1 = + 95 mm
- Traverse T6-1 = + 55 mm
- Traverse T4-2 = + 145 mm
- Traverse T5-2 = + 140 mm
- Traverse T6-2 = + 90 mm
- S200 = + 65 mm

Rollentyp

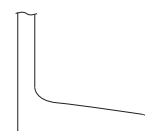

Konisch/
Schräg

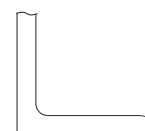

Zylindrisch/
Gerade

Bitte beachten: Der Käufer trägt die volle Verantwortung für eine korrekte Bemaßung der Grube. Außerdem muss die Grube genügend verankert und für die gewünschte Belastung konstruiert sein.

Datum:

Maßangaben von:

Händler:

Unterschrift:

PLAN DE MESURE PONT

FL - traverse de levage 6 t 12 t 16 t 20 t

SD - traverse de levage 2 t 2,6 t 3,2 t 4 t

Fabricant de l'élévateur : _____ Modèle : _____ Capacité : _____ Année : _____

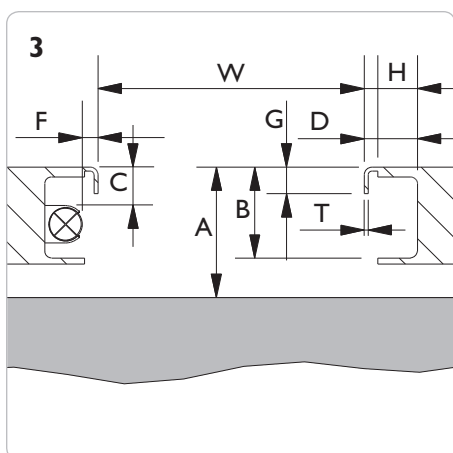
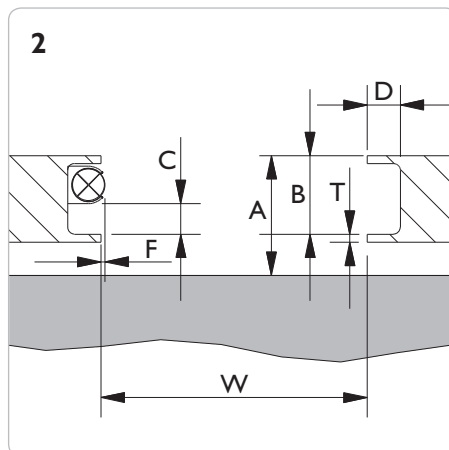
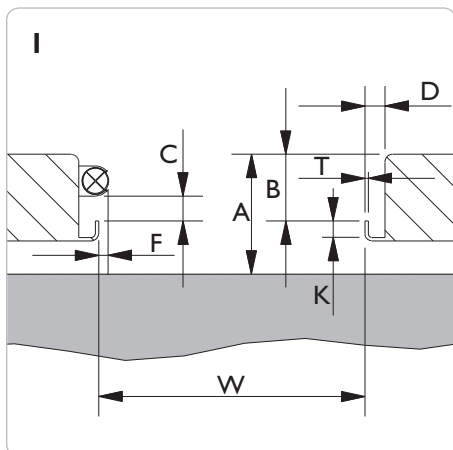

Plan n° : _____

W = _____ mm

A = _____ mm

B = _____ mm

D = _____ mm

G = _____ mm

H = _____ mm

K = _____ mm

T = _____ mm

Si l'élévateur est muni de lampes ☉ ou d'autres objets en saillie, complétez les dimensions C et F:

C min. = _____ mm

F max. = _____ mm

Profilé de rail

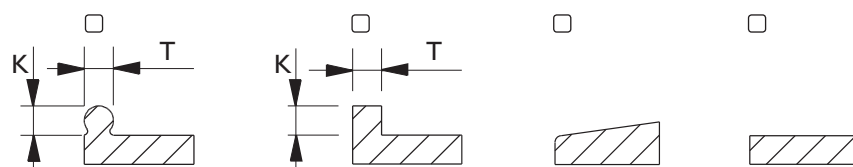

NB ! Il incombe à l'acheteur de veiller à ce que les données indiquées soient correctes et complètes. L'élévateur doit toujours être conçu et homologué pour le montage d'un cric auxiliaire. **En application de la norme EN1493:1998, la capacité du cric auxiliaire ne peut pas dépasser 0,66 x la capacité de l'élévateur** (un cric de 2 tonnes peut être monté sur un élévateur de 3 tonnes, mais pas de 2,6 tonnes).

Date : _____

Mesuré par : _____

Distributeur : _____

Signature : _____

PLAN DE MESURE FOSSE

- | | | | | | | | | |
|---|-------------------------------|-------------------------------|-------------------------------|----------------------------------|-------------------------------|--------------------------------|--------------------------------|-------------------------------|
| GD - cric de fosse | <input type="checkbox"/> 10 t | <input type="checkbox"/> 15 t | <input type="checkbox"/> 20 t | FL - traverse de levage | <input type="checkbox"/> 6 t | <input type="checkbox"/> 12 t | <input type="checkbox"/> 16 t | <input type="checkbox"/> 20 t |
| GDT - cric de fosse Télescopique | <input type="checkbox"/> 15 t | | | SD - traverse de levage | <input type="checkbox"/> 2 t | <input type="checkbox"/> 2,6 t | <input type="checkbox"/> 3,2 t | <input type="checkbox"/> 4 t |
| GGD - cric de fosse | <input type="checkbox"/> 15 t | | | ABT - traverse de soutien | <input type="checkbox"/> 20 t | | | |
| AB - traverse de soutien | <input type="checkbox"/> 20 t | | | | | | | |

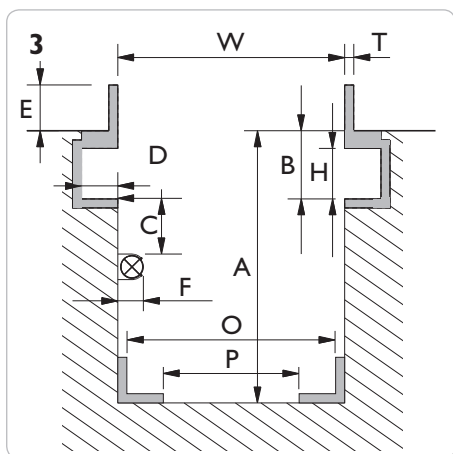
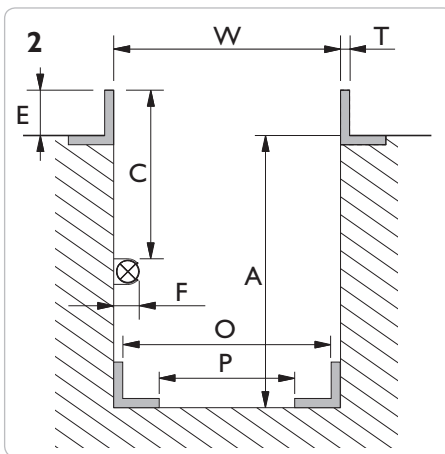
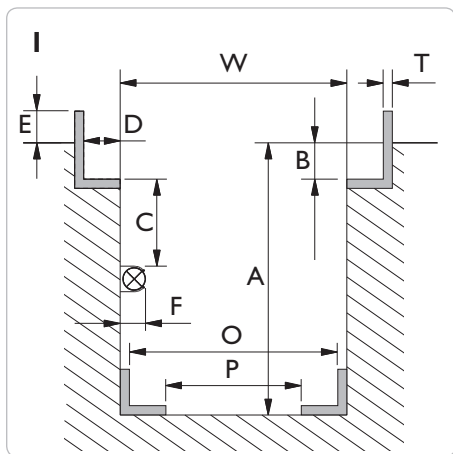

4 Plan

Plan n°: _____

Mesurez minutieusement à plusieurs endroits dans la fosse. **NB!** Écart maxi de 12 mm entre W min. et W max. sur toute la longueur de la fosse

W min. = _____ mm

W max. = _____ mm

A min. = _____ mm

B = _____ mm

D = _____ mm

E = _____ mm

H = _____ mm

T = _____ mm

Si la fosse est munie de lampes ou d'autres objets en saillie, complétez les dimensions C et F:

C min. = _____ mm

F max. = _____ mm

GGDI50S - cric de fosse

O min. = _____ mm

O max. = _____ mm

P min. = _____ mm

P max. = _____ mm

Hauteur par rapport au sol

Bord supérieur de la selle de levage **sans** accessoire (traverse, support ou rehausse) souhaité :

- au-dessus du sol de l'atelier
- au niveau du sol de l'atelier
- sous le sol de l'atelier

La tête du vérin sera positionnée +/- 50 mm selon niveau souhaité

Accessoire

Il est à noter que le montage d'une traverse ou d'un support accroît, le cas échéant, la hauteur minimum :

- Traverse T4-1 = + 100 mm
- Traverse T5-1 = + 95 mm
- Traverse T6-1 = + 55 mm
- Traverse T4-2 = + 145 mm
- Traverse T5-2 = + 140 mm
- Traverse T6-2 = + 90 mm
- S200 = + 65 mm

Type de galet / profilé de rail

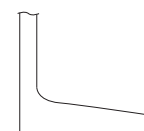

Conique/
incliné

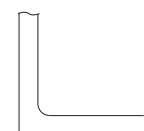

Cylindrique/
plan

NB! Il incombe à l'acheteur de veiller à ce que les données indiquées soient correctes et complètes et à ce que la fosse soit conçue pour la capacité souhaitée et suffisamment ancrée en vue de celle-ci.

Date :

Mesuré par :

Distributeur :

Signature :